













Thank you for purchasing a Harman Kardon AVR 235. This Quick-Start Guide will help you with a basic system installation. For detailed information on any step, please refer to the Owner's Manual pages referenced in this guide. We strongly recommend that you read the Owner's Manual for complete details on how to install, configure and operate the AVR 235, as well as for the important safety information it contains.

Figure 1 – Speaker Placement

The colors shown for each speaker correspond to the matching output terminal connection on the back of the AVR 235 (see page 7).

Connections Color Guide		
Audio Connections	Left	Right
Front		
Center		
Surround		
Subwoofer		
Surround Back		
Digital Audio Connections		
Coax		
Optical		
Video Connections		
Composite		
S-Video		

Match the colored jacks on the AVR 235 to the appropriate jacks on your source equipment or speakers. The colors are standardized, but not all equipment or connectors use them.

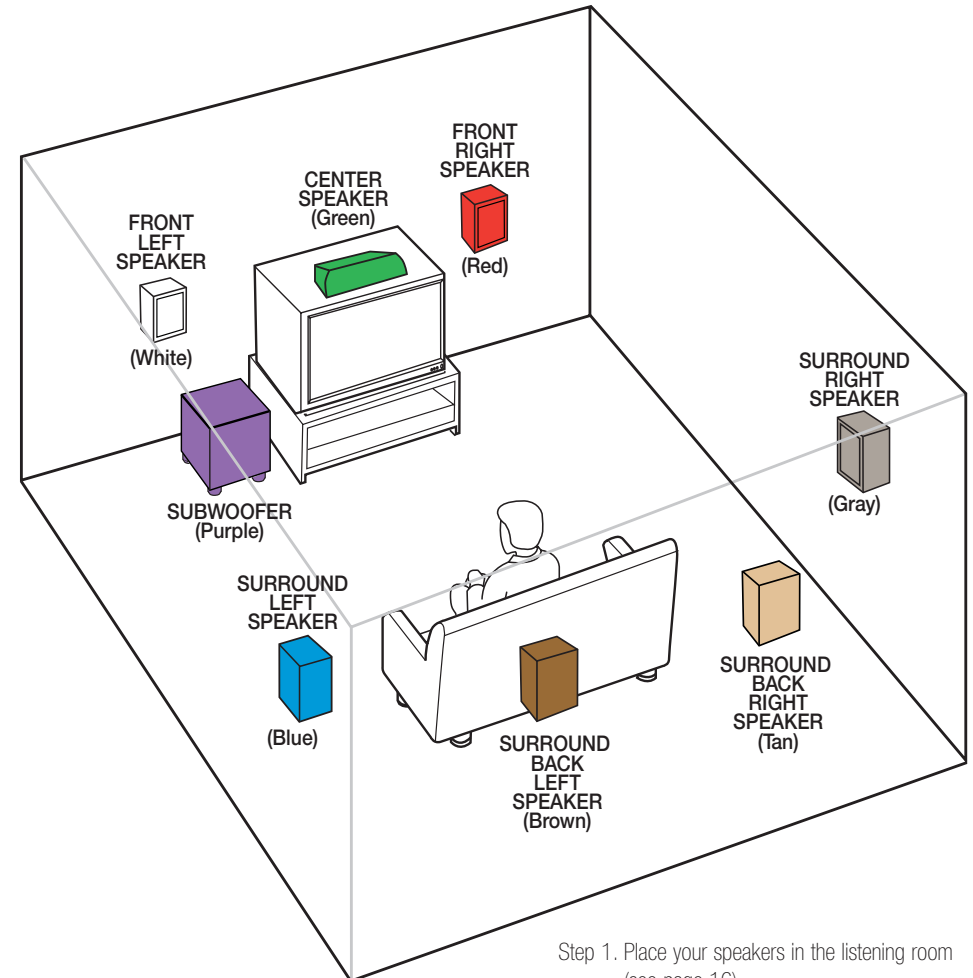

Step 1. Place your speakers in the listening room (see page 16).

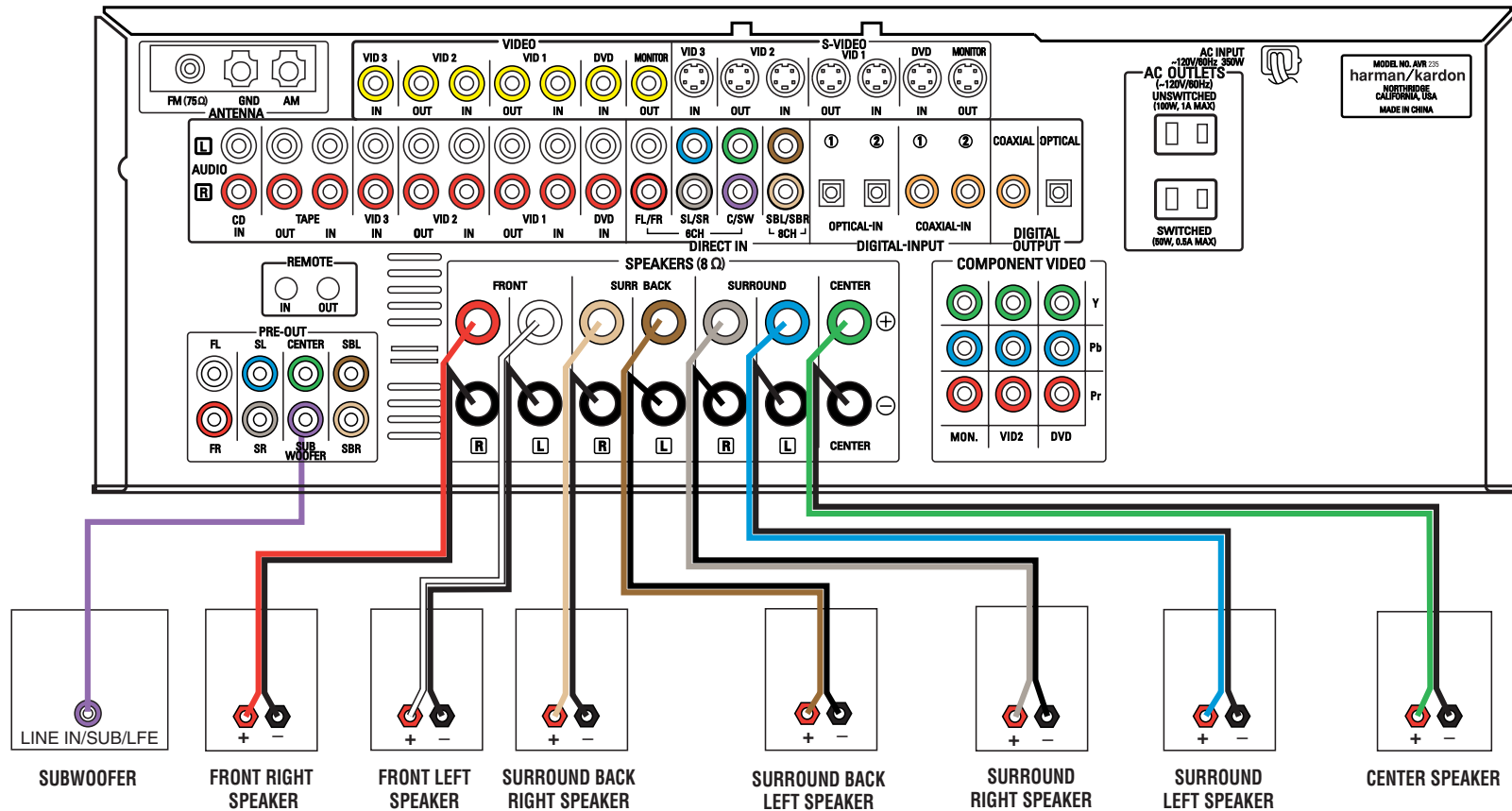

Figure 2 – Speaker Connections

Step 2. Connect the speakers to the receiver: red (+) on speaker to colored (+) on receiver and black (-) to black (-) (see page 14).

Step 3. Connect the Subwoofer Pre-Out jack to the Line-In jack on your subwoofer. You may adjust the settings on the subwoofer later as needed (see page 14).

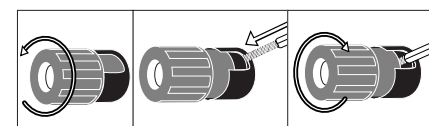

Figure 3 – How to Use the Binding-Post Speaker Terminal

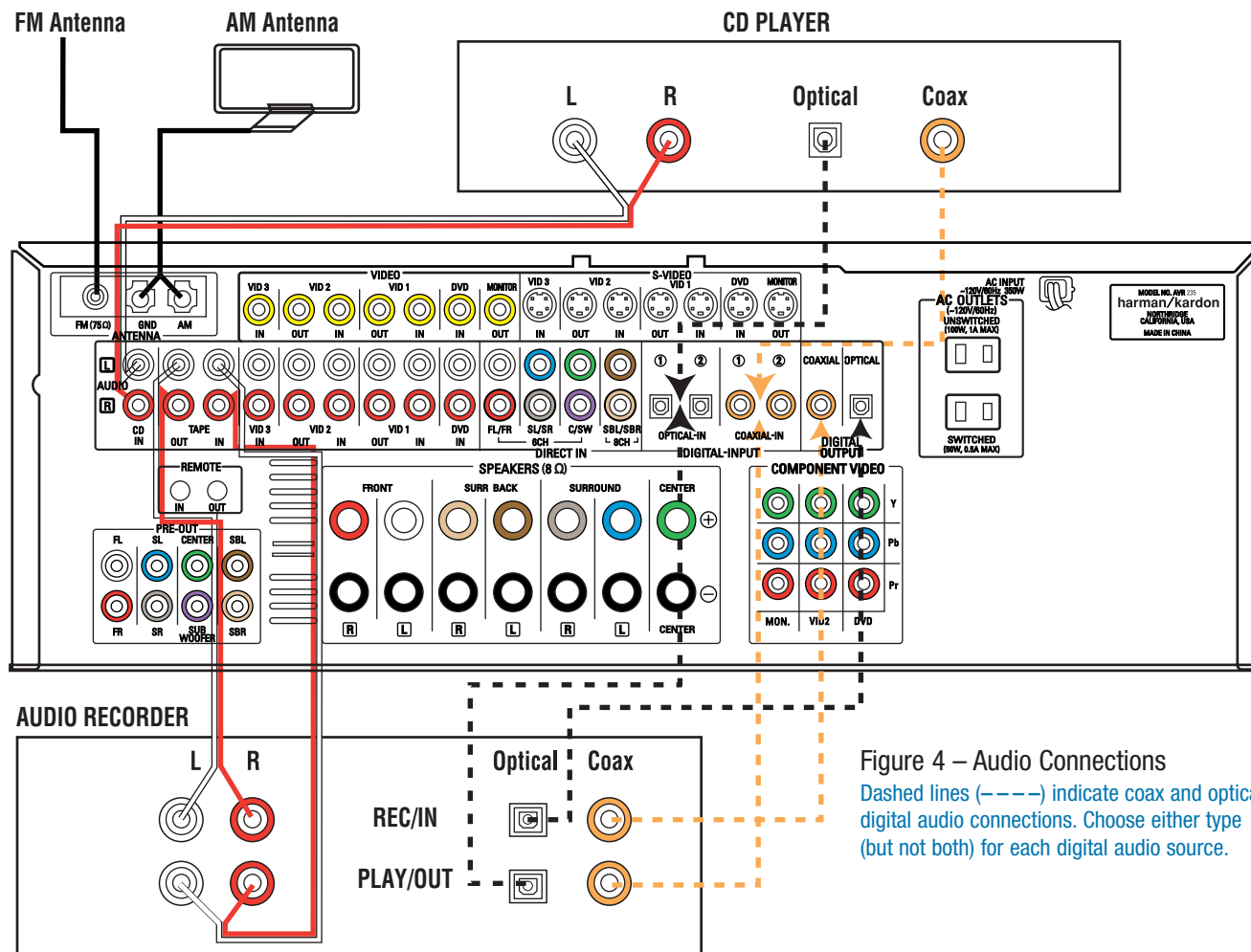

Figure 4 – Audio Connections
 Dashed lines (---) indicate coax and optical digital audio connections. Choose either type (but not both) for each digital audio source.

Step 4. Connect AM and FM antennas (Fig. 4) (see page 14).

Step 5. Connect source components, as shown in Figures 4 and 5, and the Device Connection Options chart on the back of this guide (see pages 14–15).

AUDIO connections: Right channel (red) on source to right (red) on AVR, and left channel (white) on source to left (white) on AVR.

DIGITAL AUDIO connections, if available: Choose either coax (orange) to coax (orange) OR optical to optical for each device. The Coax 1 input defaults to the DVD player, but may be reassigned. Assign the other digital inputs and outputs as appropriate for your equipment (see Step 7).

VIDEO connections: Choose component (Y/Pb/Pr – green/blue/red), composite (yellow) or S-Video (4-pin) for each video source. Connect the component, composite and S-Video Monitor outputs to

your Video Monitor (TV). Switch your TV set's input to match the type of video used for the currently selected source.

Step 6. Plug all components into AC power outlets. The outlets on the back of the AVR 235 should be used *only* for low-current products, such as CD or DVD players, and the total should not exceed 100 watts.

Basic Receiver Configuration

Step 7. **Select digital inputs:** If your DVD is connected to Coax 1, no adjustment is needed. For any other digital-device connections, use the front-panel Digital Select button and the arrow buttons to select an optical or coax digital input (see pages 18 and 28).

Step 8. **Select a surround mode:** Press the Surround Mode button on the front panel to select Dolby® Pro Logic® II – Movie. (You may select other modes later as you become familiar with the AVR 235; see pages 18–20 and 26–28.)

Step 9. **Configure speakers:** No action is needed if you have five “small” satellite-type speakers and a subwoofer. Otherwise, press the Speaker button and then the Set and arrow buttons to select the correct speaker choices for your system (see pages 20–22).

Step 10. **Use EzSet™ to set output levels:** Set the Balance to 12 o'clock, and the Volume to –10dB. Sit in the listening position and hold the remote in front of you at shoulder level, pointing at the AVR 235. Press the SPL button for 3 seconds, and release it when the LED flashes amber. Press “5” or “7” to indicate the number of speakers (not including the subwoofer). Hold the remote steady until the process is completed (see page 22).

Step 11. Your system is configured – sit back and enjoy!

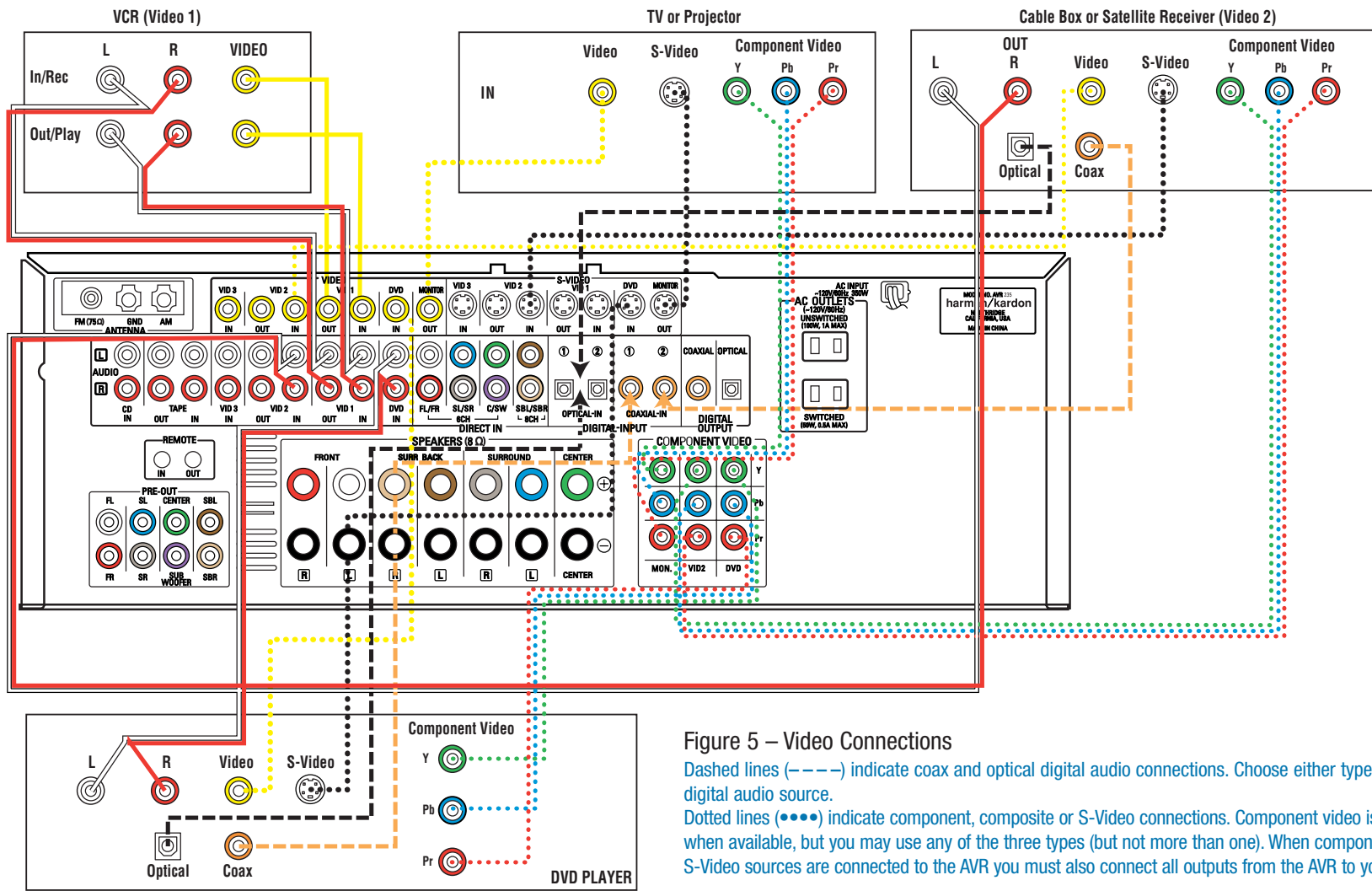

Figure 5 – Video Connections

Dashed lines (----) indicate coax and optical digital audio connections. Choose either type (but not both) for each digital audio source.
 Dotted lines (••••) indicate component, composite or S-Video connections. Component video is the preferred connection when available, but you may use any of the three types (but not more than one). When component, composite and S-Video sources are connected to the AVR you must also connect all outputs from the AVR to your TV.

Device	Input Name	Audio Input Connections	Audio Output Connections	Video Connections
CD Player	CD	CD L/R Inputs, Optical Digital 1 or 2, or Coaxial Digital 1 or 2	Not required	Not required
DVD Player	DVD	Coaxial Digital 1 or 2, Optical Digital 1 or 2, or DVD L/R Inputs	Not required	DVD Component, Composite or S-Video
VCR	Video 1	Video 1 L/R Inputs	Video 1 L/R Outputs	Video 1 Composite or S-Video Input and Output
Cable Box or Satellite Receiver	Video 2	Video 2 L/R Inputs, Optical Digital 1, 2 or 3*, or Coaxial Digital 1, 2 or 3* Inputs	Not required	Video 2 Component, Composite or S-Video Input
Audio Recorder	Tape	Tape L/R Inputs, Optical Digital 1/2** or Coaxial Digital 1/2** Inputs	Tape L/R Outputs, Digital Optical** or Coaxial Outputs**	Not required
TV or Projector	Not applicable	Not required	Not required	Monitor-Out Component, Composite and/or S-Video

* Check with your cable company to determine whether digital audio is available for all channels. It may be necessary to make BOTH analog and digital connections if it is not. ** Digital audio recorders only.